

# DENON

INTEGRATED AMPLIFIER

# PMA-710AE

---

**Owner's Manual**

**Bedienungsanleitung**

**Manuel de l'Utilisateur**

**Manuale delle istruzioni**

**Manual del usuario**

**Gebruiksaanwijzing**

**Bruksanvisning**

☐ SAFETY PRECAUTIONS



**CAUTION**  
**RISK OF ELECTRIC SHOCK**  
**DO NOT OPEN**



**CAUTION:**  
**TO REDUCE THE RISK OF ELECTRIC SHOCK, DO NOT REMOVE COVER (OR BACK). NO USER-SERVICEABLE PARTS INSIDE. REFER SERVICING TO QUALIFIED SERVICE PERSONNEL.**

The lightning flash with arrowhead symbol, within an equilateral triangle, is intended to alert the user to the presence of uninsulated "dangerous voltage" within the product's enclosure that may be of sufficient magnitude to constitute a risk of electric shock to persons.

The exclamation point within an equilateral triangle is intended to alert the user to the presence of important operating and maintenance (servicing) instructions in the literature accompanying the appliance.

**WARNING:**  
**TO REDUCE THE RISK OF FIRE OR ELECTRIC SHOCK, DO NOT EXPOSE THIS APPLIANCE TO RAIN OR MOISTURE.**

• **DECLARATION OF CONFORMITY**

We declare under our sole responsibility that this product, to which this declaration relates, is in conformity with the following standards: EN60065, EN55013, EN55020, EN61000-3-2 and EN61000-3-3. Following the provisions of 2006/95/EC and 2004/108/EC Directive.

• **ÜBEREINSTIMMUNGSERKLÄRUNG**

Wir erklären unter unserer Verantwortung, daß dieses Produkt, auf das sich diese Erklärung bezieht, den folgenden Standards entspricht: EN60065, EN55013, EN55020, EN61000-3-2 und EN61000-3-3. Entspricht den Verordnungen der Direktive 2006/95/EC und 2004/108/EC.

• **DECLARATION DE CONFORMITE**

Nous déclarons sous notre seule responsabilité que l'appareil, auquel se réfère cette déclaration, est conforme aux standards suivants: EN60065, EN55013, EN55020, EN61000-3-2 et EN61000-3-3. D'après les dispositions de la Directive 2006/95/EC et 2004/108/EC.

• **DICHIARAZIONE DI CONFORMITÀ**

Dichiariamo con piena responsabilità che questo prodotto, al quale la nostra dichiarazione si riferisce, è conforme alle seguenti normative: EN60065, EN55013, EN55020, EN61000-3-2 e EN61000-3-3. In conformità con le condizioni delle direttive 2006/95/EC e 2004/108/EC. QUESTO PRODOTTO È CONFORME AL D.M. 28/08/95 N. 548

• **DECLARACIÓN DE CONFORMIDAD**

Declaramos bajo nuestra exclusiva responsabilidad que este producto al que hace referencia esta declaración, está conforme con los siguientes estándares: EN60065, EN55013, EN55020, EN61000-3-2 y EN61000-3-3. Siguiendo las provisiones de las Directivas 2006/95/EC y 2004/108/EC.

• **EENVORMIGHEIDSVKLAARING**

Wij verklaren uitsluitend op onze verantwoordelijkheid dat dit product, waarop deze verklaring betrekking heeft, in overeenstemming is met de volgende normen: EN60065, EN55013, EN55020, EN61000-3-2 en EN61000-3-3. Volgens de bepalingen van de Richtlijnen 2006/95/EC en 2004/108/EC.

• **ÖVERENSSTÄMMELSESINTYG**

Härmed intygas helt på eget ansvar att denna produkt, vilken detta intyg avser, uppfyller följande standarder: EN60065, EN55013, EN55020, EN61000-3-2 och EN61000-3-3. Enligt stadgarna i direktiv 2006/95/EC och 2004/108/EC.

DENON EUROPE  
 Division of D&M Germany GmbH  
 An der Landwehr 19, Nettetal,  
 D-41334 Germany

**CAUTION:**

To completely disconnect this product from the mains, disconnect the plug from the wall socket outlet. The mains plug is used to completely interrupt the power supply to the unit and must be within easy access by the user.

**VORSICHT:**

Um dieses Gerät vollständig von der Stromversorgung abzutrennen, ziehen Sie bitte den Stecker aus der Wandsteckdose. Der Netzstecker wird verwendet, um die Stromversorgung zum Gerät völlig zu unterbrechen; er muss für den Benutzer gut und einfach zu erreichen sein.

**PRECAUTION:**

Pour déconnecter complètement ce produit du courant secteur, débranchez la prise de la prise murale. La prise secteur est utilisée pour couper complètement l'alimentation de l'appareil et l'utilisateur doit pouvoir y accéder facilement.

**ATTENZIONE:**

Per scollegare completamente questo prodotto dalla rete di alimentazione elettrica, scollegare la spina dalla relativa presa a muro. La spina di rete viene utilizzata per interrompere completamente l'alimentazione all'unità e deve essere facilmente accessibile all'utente.

**PRECAUCIÓN:**

Para desconectar completamente este producto de la alimentación eléctrica, desconecte el enchufe del enchufe de la pared. El enchufe de la alimentación eléctrica se utiliza para interrumpir por completo el suministro de alimentación eléctrica a la unidad y debe de encontrarse en un lugar al que el usuario tenga fácil acceso.







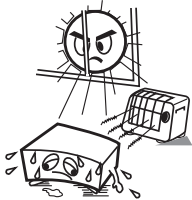
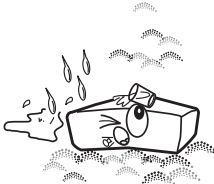

**WAARSCHUWING:**

Om de voeding van dit product volledig te onderbreken moet de stekker uit het stopcontact worden getrokken. De netstekker wordt gebruikt om de stroomtoevoer naar het toestel volledig te onderbreken en moet voor de gebruiker gemakkelijk bereikbaar zijn.

**FÖRSIKTIHETSMÅTT:**

Koppla loss stickproppen från eluttaget för att helt skilja produkten från nätet. Stickproppen används för att helt bryta strömförsörjningen till apparaten, och den måste vara lättillgänglig för användaren.

NOTE ON USE / HINWEISE ZUM GEBRAUCH / OBSERVATIONS RELATIVES A L'UTILISATION / NOTE SULL'USO / NOTAS SOBRE EL USO / ALVORENS TE GEBRUIKEN / OBSERVERA ANGÅENDE ANVÄNDNINGEN

 <ul style="list-style-type: none"> <li>• Avoid high temperatures. Allow for sufficient heat dispersion when installed in a rack.</li> <li>• Vermeiden Sie hohe Temperaturen. Beachten Sie, dass eine ausreichende Belüftung gewährleistet wird, wenn das Gerät auf ein Regal gestellt wird.</li> <li>• Eviter des températures élevées. Tenir compte d'une dispersion de chaleur suffisante lors de l'installation sur une étagère.</li> <li>• Evitate di esporre l'unità a temperature elevate. Assicuratevi che vi sia un'adeguata dispersione del calore quando installate l'unità in un mobile per componenti audio.</li> <li>• Evite altas temperaturas. Permite la suficiente dispersión del calor cuando está instalado en la consola.</li> <li>• Vermijd hoge temperaturen. Zorg er bij installatie in een audiorack voor, dat de door het toestel geproduceerde warmte goed kan worden afgevoerd.</li> <li>• Undvik höga temperaturer. Se till att det finns möjlighet till god värmeavledning vid monteringen i ett rack.</li> </ul>	 <ul style="list-style-type: none"> <li>• Keep the unit free from moisture, water, and dust.</li> <li>• Halten Sie das Gerät von Feuchtigkeit, Wasser und Staub fern.</li> <li>• Protéger l'appareil contre l'humidité, l'eau et la poussière.</li> <li>• Tenete l'unità lontana dall'umidità, dall'acqua e dalla polvere.</li> <li>• Mantenga el equipo libre de humedad, agua y polvo.</li> <li>• Laat geen vochtigheid, water of stof in het apparaat binnendringen.</li> <li>• Utsätt inte apparaten för fukt, vatten och damm.</li> </ul>	 <ul style="list-style-type: none"> <li>• Do not let foreign objects into the unit.</li> <li>• Lassen Sie keine fremden Gegenstände in das Gerät kommen.</li> <li>• Ne pas laisser des objets étrangers dans l'appareil.</li> <li>• Non inserite corpi estranei all'interno dell'unità.</li> <li>• No deje objetos extraños dentro del equipo.</li> <li>• Laat geen vreemde voorwerpen in dit apparaat vallen.</li> <li>• Se till att främmande föremål inte tränger in i apparaten.</li> </ul>	<p><b>CAUTION:</b></p> <ul style="list-style-type: none"> <li>• The ventilation should not be impeded by covering the ventilation openings with items, such as newspapers, tablecloths, curtains, etc.</li> <li>• No naked flame sources, such as lighted candles, should be placed on the unit.</li> <li>• Observe and follow local regulations regarding battery disposal.</li> <li>• Do not expose the unit to dripping or splashing fluids.</li> <li>• Do not place objects filled with liquids, such as vases, on the unit.</li> </ul> <p><b>ACHTUNG:</b></p> <ul style="list-style-type: none"> <li>• Die Belüftung soll te auf keinen Fall durch das Abdecken der Belüftungsöffnungen durch Gegenstände wie beispielsweise Zeitungen, Tischtücher, Vorhänge o. Ä. behindert werden.</li> <li>• Auf dem Gerät sollten keinerlei direkte Feuerquellen wie beispielsweise angezündete Kerzen aufgestellt werden.</li> <li>• Bitte beachten Sie bei der Entsorgung der Batterien die örtlich geltenden Umweltabestimmungen.</li> <li>• Das Gerät sollte keiner tropfenden oder spritzenden Flüssigkeit ausgesetzt werden.</li> <li>• Auf dem Gerät sollten keine mit Flüssigkeit gefüllten Behälter wie beispielsweise Vasen aufgestellt werden.</li> </ul>
 <ul style="list-style-type: none"> <li>• Handle the power cord carefully. Hold the plug when unplugging the cord.</li> <li>• Gehen Sie vorsichtig mit dem Netzkabel um. Halten Sie das Kabel am Stecker, wenn Sie den Stecker herausziehen.</li> <li>• Manipuler le cordon d'alimentation avec précaution. Tenir la prise lors du débranchement du cordon.</li> <li>• Maneggiare il cavo di alimentazione con attenzione. Tenete ferma la spina quando scollegate il cavo dalla presa.</li> <li>• Maneje el cordón de energía con cuidado. Sostenga el enchufe cuando desconecte el cordón de energía.</li> <li>• Hanteer het netsnoer voorzichtig. Houd het snoer bij de stekker vast wanneer deze moet worden aangesloten of losgekoppeld.</li> <li>• Hantera nätkablen varsamt. Håll i kablarna när den kopplas från el-uttaget.</li> </ul>	 <ul style="list-style-type: none"> <li>• Unplug the power cord when not using the unit for long periods of time.</li> <li>• Wenn das Gerät längere Zeit nicht verwendet werden soll, trennen Sie das Netzkabel vom Netzstecker.</li> <li>• Débrancher le cordon d'alimentation lorsque l'appareil n'est pas utilisé pendant de longues périodes.</li> <li>• Scollegate il cavo di alimentazione quando prevedete di non utilizzare l'unità per un lungo periodo di tempo.</li> <li>• Desconecte el cordón de energía cuando no uti ice el equipo por mucho tiempo.</li> <li>• Neem altijd het netsnoer uit het stopcontact wanneer het apparaat gedurende een lange periode niet wordt gebruikt.</li> <li>• Koppla loss nätkablen om apparaten inte kommer att användas i lång tid.</li> </ul>	 <ul style="list-style-type: none"> <li>• Do not let insecticides, benzene, and thinner come in contact with the unit.</li> <li>• Lassen Sie das Gerät nicht mit Insektiziden, Benzin oder Verdünnungsmitteln in Berührung kommen.</li> <li>• Ne pas mettre en contact des insecticides, du benzène et un diluant avec l'appareil.</li> <li>• Assicuratevi che l'unità non entri in contatto con insetticidi, benzolo o solventi.</li> <li>• No permita el contacto de insecticidas, gaso ina y diluyentes con el equipo.</li> <li>• Voorkom dat insecticiden, benzeen of verververdunner met dit toestel in contact komen.</li> <li>• Se till att inte insektsmedel på spraybruk, bensen och thinner kommer i kontakt med apparatens höje.</li> </ul>	<p><b>ATTENTION:</b></p> <ul style="list-style-type: none"> <li>• La ventilation ne doit pas être gênée en recouvrant les ouvertures de la ventilation avec des objets tels que journaux, rideaux, tissus, etc.</li> <li>• Aucune flamme nue, par exemple une bougie, ne doit être placée sur l'appareil.</li> <li>• Veuillez à respecter les lois en vigueur lorsque vous jetez les piles usagées.</li> <li>• L'appareil ne doit pas être exposé à l'eau ou à l'humidité.</li> <li>• Ne pas poser d'objet contenant du liquide, par exemple un vase, sur l'appareil.</li> </ul> <p><b>ATTENZIONE:</b></p> <ul style="list-style-type: none"> <li>• Le aperture di ventilazione non devono essere ostruite coprendole con oggetti, quali giornali, tovaglie, tende e così via.</li> <li>• Non posizionate sull'unità fiamme libere, come ad esempio candele accese.</li> <li>• Prestate attenzione agli aspetti legati alla tutela dell'ambiente nello smaltimento delle batterie.</li> <li>• L'apparecchiatura non deve essere esposta a gocce o spruzzi.</li> <li>• Non posizionate sull'unità alcun oggetto contenente liquidi, come ad esempio i vasi.</li> </ul> <p><b>PRECAUCIÓN:</b></p> <ul style="list-style-type: none"> <li>• La ventilación no debe quedar obstruida por haberse cubierto las aperturas con objetos como periódicos, manteles, cortinas, etc.</li> <li>• No debe colocarse sobre el aparato ninguna fuente inflamable sin protección, como velas encendidas.</li> <li>• A la hora de deshacerse de las pilas, respete la normativa para el cuidado del medio ambiente.</li> <li>• No exponer el aparato al goteo o salpicaduras cuando se uti ice.</li> <li>• No colocar sobre el aparato objetos llenos de líquido, como jarros.</li> </ul>
 <p>* (For apparatuses with ventilation holes)</p> <ul style="list-style-type: none"> <li>• Do not obstruct the ventilation holes.</li> <li>• Decken Sie den Lüftungsbereich nicht ab.</li> <li>• Ne pas obstruer les trous d'aération.</li> <li>• Non coprite i fori di ventilazione.</li> <li>• No obstruya los orificios de ventilación.</li> <li>• De ventilatieopeningen mogen niet worden geblokkeerd.</li> <li>• Täpp inte till ventilationsöppningarna.</li> </ul>	 <p>* (For apparatuses with ventilation holes)</p> <ul style="list-style-type: none"> <li>• Do not obstruct the ventilation holes.</li> <li>• Decken Sie den Lüftungsbereich nicht ab.</li> <li>• Ne pas obstruer les trous d'aération.</li> <li>• Non coprite i fori di ventilazione.</li> <li>• No obstruya los orificios de ventilación.</li> <li>• De ventilatieopeningen mogen niet worden geblokkeerd.</li> <li>• Täpp inte till ventilationsöppningarna.</li> </ul>	 <ul style="list-style-type: none"> <li>• Never disassemble or modify the unit in any way.</li> <li>• Versuchen Sie niemals das Gerät auseinander zu nehmen oder zu verändern.</li> <li>• Ne jamais démonter ou modifier l'appareil d'une manière ou d'une autre.</li> <li>• Non smontare né modificare l'unità in alcun modo.</li> <li>• Nunca desarme o modifique el equipo de ninguna manera.</li> <li>• Dit toestel mag niet gedemonteerd of aangepast worden.</li> <li>• Ta inte isär apparaten och försök inte bygga om den.</li> </ul>	<p><b>WAARSCHUWING:</b></p> <ul style="list-style-type: none"> <li>• De ventilatie mag niet worden belemmerd door de ventilatieopeningen af te dekken met bijvoorbeeld kranten, een tafelkleed, gordijnen, enz.</li> <li>• Plaats geen open vlammen, bijvoorbeeld een brandende kaars, op het apparaat.</li> <li>• Houd u steeds aan de milieuvoorschriften wanneer u gebruikte batterijen wegdoet.</li> <li>• Stel het apparaat niet bloot aan druppels of spatten.</li> <li>• Plaats geen voorwerpen gevuld met water, bijvoorbeeld een vaas, op het apparaat.</li> </ul> <p><b>OBSERVERA:</b></p> <ul style="list-style-type: none"> <li>• Ventilationen bör inte förhindras genom att täcka för ventilationsöppningarna med föremål såsom tidningar, bordsdukar, gardiner osv.</li> <li>• Inga blottade brandkällor, såsom tända jus, får placeras på apparaten.</li> <li>• Tänk på miljöaspekterna när du bortskaffar batterier.</li> <li>• Apparaten får inte utsättas för vätska.</li> <li>• Placera inte föremål fyllda med vätska, t ex. vasar, på apparaten.</li> </ul>

**A NOTE ABOUT RECYCLING:**

This product's packaging materials are recyclable and can be reused. Please dispose of any materials in accordance with the local recycling regulations.

When discarding the unit, comply with local rules or regulations.

Batteries should never be thrown away or incinerated but disposed of in accordance with the local regulations concerning battery disposal.

This product and the supplied accessories, excluding the batteries, constitute the applicable product according to the WEEE directive.



Pb

**HINWEIS ZUM RECYCLING:**

Das Verpackungsmaterial dieses Produktes ist zum Recyceln geeignet und kann wieder verwendet werden. Bitte entsorgen Sie alle Materialien entsprechend der örtlichen Recycling-Vorschriften.

Beachten Sie bei der Entsorgung des Gerätes die örtlichen Vorschriften und Bestimmungen.

Die Batterien dürfen nicht in den Hausmüll geworfen oder verbrannt werden; bitte entsorgen Sie die Batterien gemäß der örtlichen Vorschriften.

Dieses Produkt und das im Lieferumfang enthaltene Zubehör (mit Ausnahme der Batterien!) entsprechen der WEEE-Direktive.

**UNE REMARQUE CONCERNANT LE RECYCLAGE:**

Les matériaux d'emballage de ce produit sont recyclables et peuvent être réutilisés. Veuillez disposer des matériaux conformément aux lois sur le recyclage en vigueur.

Lorsque vous mettez cet appareil au rebut, respectez les lois ou réglementations en vigueur.

Les piles ne doivent jamais être jetées ou incinérées, mais mises au rebut conformément aux lois en vigueur sur la mise au rebut des piles.

Ce produit et les accessoires inclus, à l'exception des piles, sont des produits conformes à la directive DEEE.

**NOTA RELATIVA AL RICICLAGGIO:**

I materiali di imballaggio di questo prodotto sono riutilizzabili e riciclabili. Smaltire i materiali conformemente alle normative locali sul riciclaggio.

Per lo smaltimento dell'unità, osservare le normative o le leggi locali in vigore.

Non gettare le batterie, né incenerirle, ma smaltirle conformemente alla normativa locale sui rifiuti chimici.

Questo prodotto e gli accessori inclusi nell'imballaggio sono applicabili alla direttiva RAEE, ad eccezione delle batterie.

**ACERCA DEL RECICLAJE:**

Los materiales de embalaje de este producto son reciclables y se pueden volver a utilizar. Disponga de estos materiales siguiendo los reglamentos de reciclaje de su localidad.

Cuando se deshaga de la unidad, cumpla con las reglas o reglamentos locales.

Las pilas nunca deberán tirarse ni incinerarse. Deberá disponer de ellas siguiendo los reglamentos de su localidad relacionados con los desperdicios químicos.

Este producto junto con los accesorios empaquetados es el producto aplicable a la directiva RAEE excepto pilas.

**EEN AANTEKENING MET BETREKKING TOT DE RECYCLING:**

Het inpakmateriaal van dit product is recycleerbaar en kan opnieuw gebruikt worden. Er wordt verzocht om zich van elk afvalmateriaal te ontdoen volgens de plaatselijke voorschriften.

Volg voor het wegdoen van de speler de voorschriften voor de verwijdering van wit- en bruingoed op.

Batterijen mogen nooit worden weggegooid of verbrand, maar moeten volgens de plaatselijke voorschriften betreffende chemisch afval worden verwijderd.

Op dit product en de meegeleverde accessoires, m.u.v. de batterijen is de richtlijn voor afgedankte elektrische en elektronische apparaten (WEEE) van toepassing.

**OBSERVERA ANGÅENDE ÅTERVINNING:**

Produktens emballage är återvinningsbart och kan återanvändas. Kassera det enligt lokala återvinningsbestämmelser.

När du kasserar enheten ska du göra det i överensstämmelse med lokala regler och bestämmelser.

Batterier får absolut inte kastas i soporna eller brännas. Kassera dem enligt lokala bestämmelser för kemiskt avfall.

Denna apparat och de tillbehör som levereras med den uppfyller gällande WEEE-direktiv, med undantag av batterierna.

■ Contents

<b>Getting Started</b>	
Main Features .....	1
Accessories .....	1
Cautions on Installation .....	1
Cautions on Handling .....	2
About the Remote Control Unit .....	2
Inserting the Batteries .....	2
Operating Range of the Remote Control Unit .....	2
Part Names and Functions .....	3
Front Panel .....	3
Rear Panel .....	3
Remote Control Unit .....	4
<b>Connections</b>	
Preparations .....	5
Cables Used for Connections .....	5
Connecting the Audio Equipment .....	5
Connecting the Speakers .....	5
Connecting the Speaker Cables .....	5
Speaker Connections .....	6
Connecting Players .....	6
Connecting Recorders .....	7
Connecting the Power Cord .....	7
<b>Operation</b>	
Preparations Prior to Playing .....	8
Starting Playback .....	8
Starting Recording .....	8
Copying Recorders .....	8
<b>Troubleshooting</b> .....	
<b>Specifications</b> .....	
<b>Index</b> .....	

# Getting Started

Thank you for purchasing this DENON product. To ensure proper operation, please read this owner's manual carefully before using the product.  
After reading them, be sure to keep them for future reference.

## Main Features

- 1. HC (High-Current) single push-pull circuit installed to simultaneously achieve both "subtlety" and "powerfulness"**  
Employs HC transistors that pass 2 ~ 3 times the peak current of conventional audio power transistors, to acquire a stable, expressive quality of music from extremely low-levels to high volume.
- 2. High-speed, large current capacity power circuit**  
To draw out the full potential of the HC single push-pull circuit, the power circuit uses DENON custom-specification block type electrolytic capacitors, as well as SBD (Schottky-Barrier Diode) with short reverse recovery time and minimal current noise.
- 3. Source Direct function, for pure audio playback**  
Achieves pure audio playback, protecting the purity of the sound by by-passing TONE (BASS, TREBLE), LOUDNESS and BALANCE controls.
- 4. Reduced power consumption during standby**  
In consideration of the environment, power consumption during standby has been reduced to 0.3 W or better.

## Accessories

Check that the following parts are supplied with the product.

- |                                       |   |
|---------------------------------------|---|
| ① Owner's manual .....                | 1 |
| ② Service station list .....          | 1 |
| ③ Remote control unit (RC-1131) ..... | 1 |
| ④ R03/AAA batteries .....             | 2 |

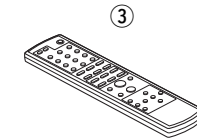

## Cautions on Installation

**Note:**  
For heat dispersal, do not install this unit in a confined space such as a bookcase or similar enclosure.

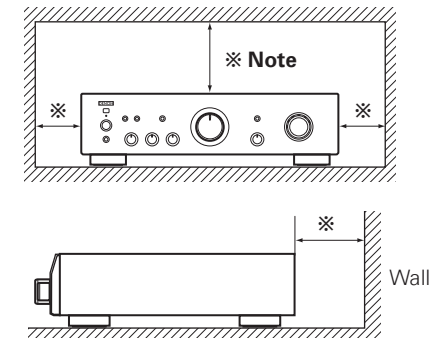

## Cautions on Handling

### • Before turning the power switch on

Check once again that all connections are correct and that there are no problems with the connection cables.

- Power is supplied to some of the circuitry even when the unit is set to the standby mode. When traveling or leaving home for long periods of time, be sure to unplug the power cord from the power outlet.

### • About condensation

If there is a major difference in temperature between the inside of the unit and the surroundings, condensation (dew) may form on the operating parts inside the unit, causing the unit not to operate properly.

If this happens, let the unit sit for an hour or two with the power turned off and wait until there is little difference in temperature before using the unit.

### • Cautions on using mobile phones

Using a mobile phone near this unit may result in noise. If so, move the mobile phone away from this unit when it is in use.

### • Moving the unit

Turn off the power and unplug the power cord from the power outlet.

Next, disconnect the connection cables to other system units before moving the unit.

- Note that the illustrations in these instructions may differ from the actual unit for explanation purposes.

## About the Remote Control Unit

The included remote control unit can be used to control DENON CD players and tuners.

※ Some products may not be operable.

### Inserting the Batteries

- ① Remove the remote control unit's rear cover.

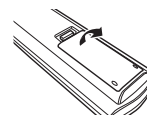

- ② Set two R03/AAA batteries in the battery compartment in the indicated direction.

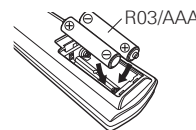

- ③ Put the rear cover back on.

#### NOTE

- Replace the batteries with new ones if the set does not operate even when the remote control unit is operated close to the unit.
- The supplied batteries are only for verifying operation.
- When inserting the batteries, be sure to do so in the proper direction, following the "⊕" and "⊖" marks in the battery compartment.
- To prevent damage or leakage of battery fluid:
  - Do not use a new battery together with an old one.
  - Do not use two different types of batteries.
  - Do not attempt to charge dry batteries.
  - Do not short-circuit, disassemble, heat or dispose of batteries in flames.
- If the battery fluid should leak, carefully wipe the fluid off the inside of the battery compartment and insert new batteries.
- Remove the batteries from the remote control unit if it will not be in use for long periods.
- Used batteries should be disposed of in accordance with the local regulations regarding battery disposal.

## Operating Range of the Remote Control Unit

Point the remote control unit at the remote sensor when operating it.

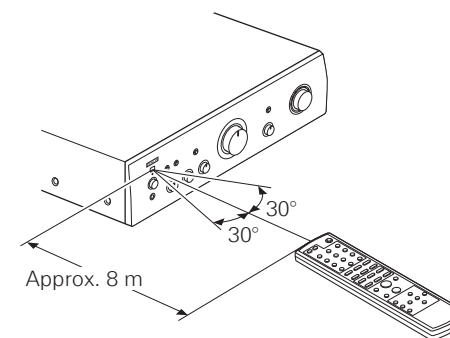

#### NOTE

The set may function improperly or the remote control unit may not operate if the remote control sensor is exposed to direct sunlight, strong artificial light from an inverter type fluorescent lamp or infrared light.

# Part Names and Functions

For buttons not explained here, see the page indicated in parentheses ( ).

## Front Panel

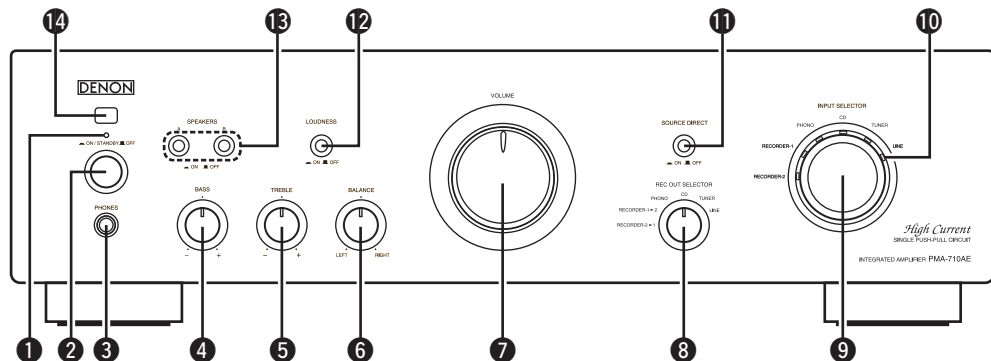

- 1 Power indicator**  
Changes as shown below according to PMA-710AE's status.
  - For several seconds after the power is turned on ..... Red (blinking)
  - Power "ON" ..... Green
  - Muting ..... Red (blinking)
  - Standby ..... Red
  - Power "OFF" ..... Off
- 2 Power switch (ON/STANDBY OFF)**  
When set to "ON/STANDBY", the power turns on, and when set to "OFF", the power turns off.
- 3 Headphones jack (PHONES)**
- 4 BASS control knob**
- 5 TREBLE control knob**
- 6 BALANCE control knob**
- 7 VOLUME control knob**
- 8 REC OUT SELECTOR knob**
- 9 INPUT SELECTOR knob**  
Use this to select the source that you wish to listen to.
- 10 Input indicator**  
The selected input is shown with an orange indicator.

- 11 SOURCE DIRECT switch**  
When set to "ON", the signals do not pass through the tone adjustment circuitry (bass, treble, balance and loudness), resulting in playback with higher sound quality. When set to "OFF", the sound can be adjusted to your tastes.
- 12 LOUDNESS switch**  
When listening with the volume turned low, set this to "ON" to amplify the bass and treble sound that is hard to hear when the volume is low and achieve a more natural sound.
- 13 SPEAKERS A/B switches**
  - When A (or B) is set to "ON", sound is produced from the speakers connected to the A (or B) speaker output terminals.
  - When both A and B are set to "ON", sound is produced from the speakers connected to both the A and B speaker output terminals.
  - When both A and B are set to "OFF", no sound is produced from the speakers. Use this when listening over headphones.
- 14 Remote control sensor**



- When the **VOLUME** control knob is set just beyond the "12 o'clock" position (over halfway), the adjustments that can be made with the **BASS** and **TREBLE** controls is decreased.
- When the **VOLUME** control knob is set to maximum or turned fully clockwise, the base and treble can no longer be adjusted.

### NOTE

Functions **4**, **5**, **6** and **12** are only available when the **SOURCE DIRECT** switch is set to "OFF".

## Rear Panel

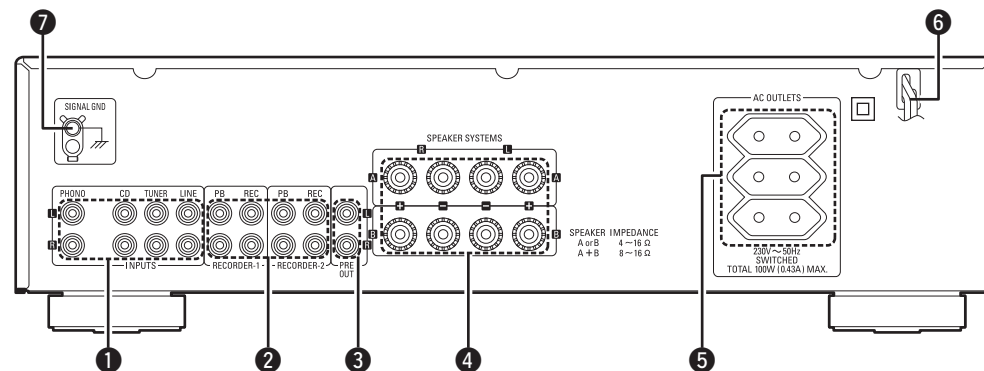

- 1 Input terminals (INPUTS)**  
Connect your source equipment here.
- 2 Recording input/output terminals (RECORDER-1 and RECORDER-2)**  
Connect your recording equipment here.
- 3 PRE OUT terminals**  
Use this to add such equipment as a power amplifier or subwoofer.
- 4 Speaker system terminals (SPEAKER SYSTEMS)**  
Connect your speakers here.
- 5 AC OUTLETS**  
Use this as the power outlets for other audio devices. Check equipment power requirement ratings before use (see the ratings as marked on the rear panel). If in doubt consult with your dealer or DENON distributor.
- 6 Power cord**
- 7 SIGNAL GND (ground) terminal**  
Connect the ground wire from your turntable here.

### NOTE

- This terminal is not a safety ground.
- NEVER insert the short-circuiting pin plug into the recording output or PRE OUT terminals. Doing so could result in damage.

# Remote Control Unit

Getting Started

Connections

Operation

Troubleshooting

Specifications

**Amplifier operating buttons**

**POWER button**  
This operates the main unit's power.

**Input source selector buttons**  
These switch the input source.

**MUTING button**  
Press this to mute the sound.  
The power indicator on the main unit blinks red.  
Press again to produce sound.

**Volume adjust buttons**  
These adjust the volume.

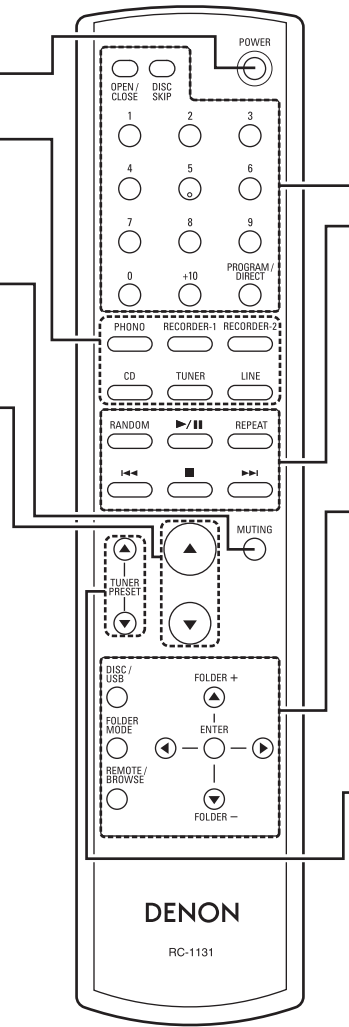

**DENON product operating buttons**

**CD player block**

**OPEN/CLOSE** : Press this button to open and close the disc tray.

**DISK SKIP** : This button selects the disc, when using a DENON multi-disc CD player.

**0 ~ 9, +10** : Number buttons

**PROGRAM/DIRECT** : Press this button to switch between PROGRAM and DIRECT play.

**RANDOM** : Random playback

**▶/||** : Play / Pause

**REPEAT** : Repeat playback

**◀◀** : Reverse-skip

**■** : Stop

**▶▶** : Forward-skip

**DISC/USB** : Press this button to select "DISC" or "USB".

**FOLDER MODE** : Press this button to select "Folder Mode" or "Disc Mode".

**REMOTE/BROWSE** : Press this button to select the display mode.

**ENTER** : Enter button

**FOLDER +/-** : Press this button to select the file to be played.

△▽◀▶ : Cursor buttons

**TUNER block**

**TUNER PRESET ▲, ▼**  
These switch the preset channel.



- The included remote control unit can be used to operate DENON CD players and tuners.
- When using it, also refer to the operating instructions of the other devices.
- Some products may not be operable.



# Connections

Connections for all compatible audio signal format is described in this operating instructions. Please select the types of connections suited for the equipment you are connecting.

**NOTE**

- Do not plug in the power cord until all connections have been completed.
- When making connections, also refer to the operating instructions of the other components.
- Be sure to connect the left and right channels properly (left with left, right with right).
- Do not bundle power cords together with connection cables. Doing so can result in humming or noise.
- Do not turn up the volume when no turntable is connected to the PHONO input terminals. Doing so will cause humming or noise.

## Preparations

### Cables Used for Connections

Select the cables according to the equipment being connected.

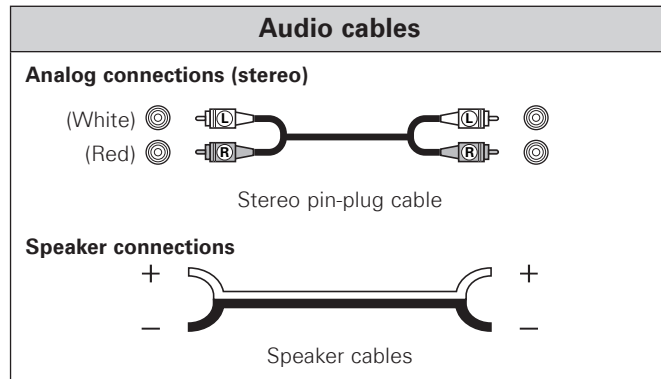

## Connecting the Audio Equipment

**Cautions on playing SA sources:**

When regular speakers not compatible with SA sources (DVD Audio discs, Super Audio CDs and other sources including treble components above the audible range), set the properties of the player (DVD Audio player, Super Audio CD player, etc.) for use with regular speakers (or amplifiers).  
The speakers may be damaged if the volume is set too high when playing SA sources. For instructions on setting the player, refer to the operating instructions included with the player.

## Connecting the Speakers

### Connecting the Speaker Cables

Carefully check the left (L) and right (R) channels and + (red) and - (black) polarities on the speakers being connected to the PMA-710AE, and be sure to interconnect the channels and polarities correctly.

**1** Peel off about 10 mm of sheathing from the tip of the speaker cable, then either twist the core wire tightly or terminate it.



**2** Turn the speaker terminal counterclockwise to loosen it.



**3** Insert the speaker cable's core wire to the hilt into the speaker terminal.



**4** Turn the speaker terminal clockwise to tighten it.



**NOTE**

- Connect the speaker cables in such a way that they do not stick out of the speaker terminals. The protection circuit may be activated if the core wires touch the rear panel or if the + and - sides touch each other (☞ "Protection circuit").
- Never touch the speaker terminals while the power supply is connected. Doing so could result in electric shock.

**Speaker impedance**

Use speakers with impedances within the ranges shown below according to their usage conditions.

Speakers used	Impedance
A or B	4 ~ 16 Ω/ohms
A and B	8 ~ 16 Ω/ohms

### Protection circuit

- The protection circuit will be activated in the following cases:
- When the speaker cable's core wires are touching the rear panel or screws or when the speaker cable's + and - sides are touching
  - When the surrounding temperature is extremely high
  - When the internal temperature rises due to extended use with a high output

If this happens, unplug the power cord, then check the connections of the speaker cables and input cables. If the set's temperature is extremely high, wait for it to cool off and improve surrounding ventilation. After doing this, plug the power cord back in.

If the protection circuit is activated though there are no problems in ventilation around the set or in connections, the set could be damaged. Turn off the power, then contact a DENON servicing and inquiry outlet.

## Speaker Connections

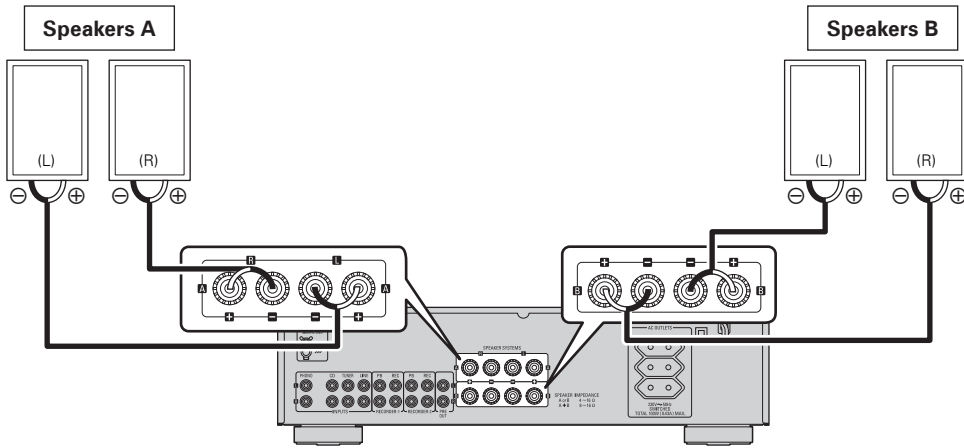

### Bi-wiring Connection

- When bi-wiring with bi-wireable speakers connect the mid and high range terminals to SYSTEM (A) (or SYSTEM (B)), the low range terminals to SYSTEM (B) (or SYSTEM (A)). This enables playback with minimized interference between high-range speaker unit and low-range speaker unit.
- Set both the **SPEAKER A/B** switches to "ON".

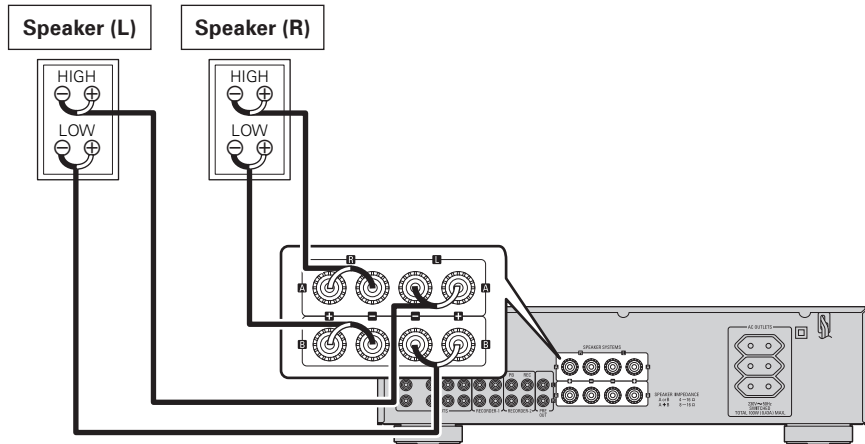

## Connecting Players

- Only Turntables fitted with a MM (Moving Magnet) cartridge can be used with this unit. If you have an MC (Moving Coil) cartridge you will need to use a commercially available head amplifier or step-up transformer.
- If humming or other noise is generated when the ground wire is connected, disconnect it.

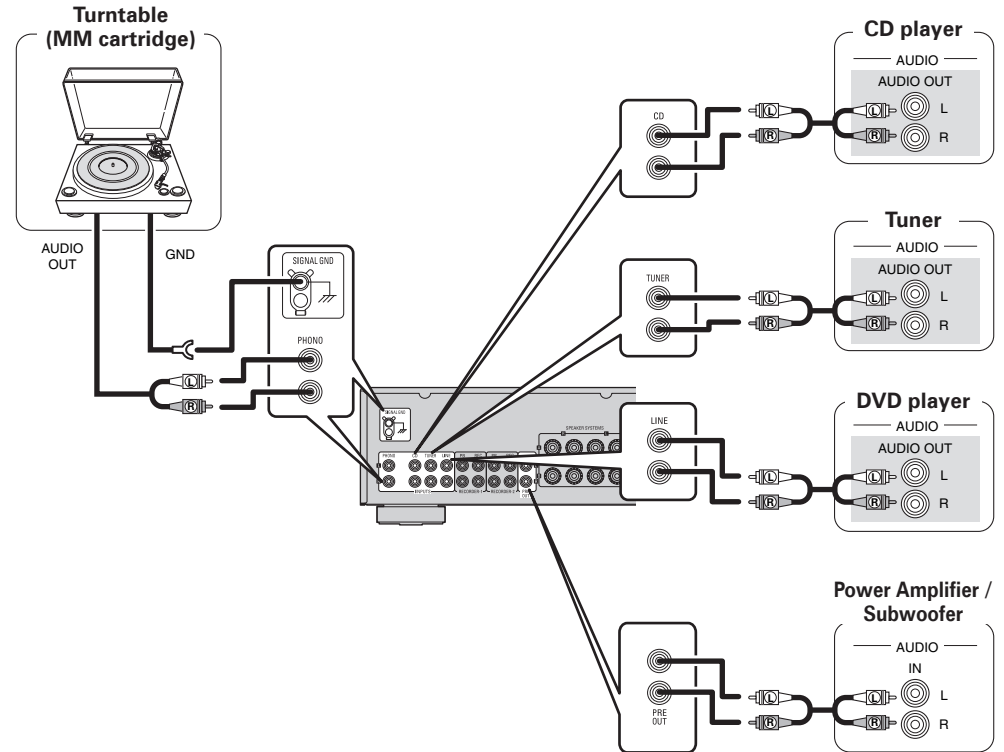

## Connecting Recorders

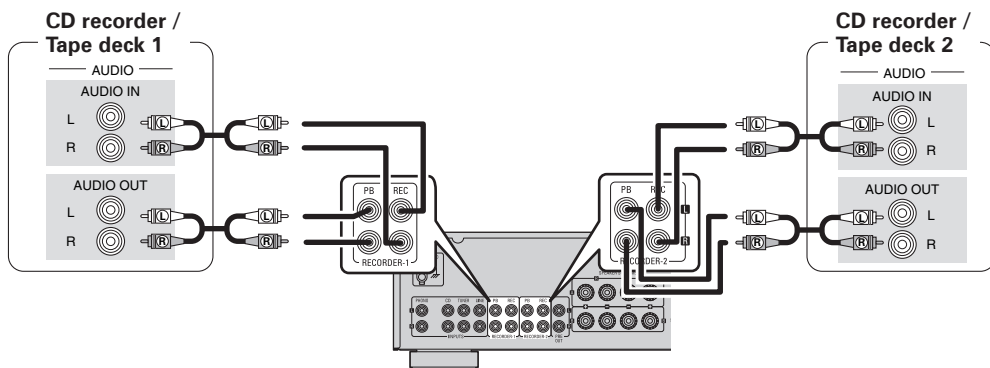

## Connecting the Power Cord

Wait until all connections have been completed before connecting the power cord.

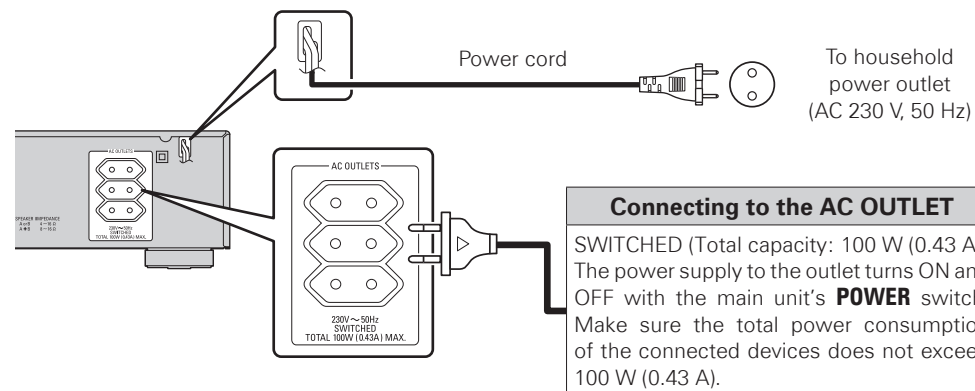

### NOTE

- Only use the AC OUTLET for audio equipment. Never use it for hair driers, TVs or other electrical appliances.
- Insert the plugs securely. Incomplete connections will result in the generation of noise.

# Operation

**Symbols used to indicate buttons in this manual**

- Button located on both the main unit and the remote control unit → **BUTTON**
- Button only on the main unit → **<BUTTON>**
- Button only on the remote control unit → **[BUTTON]**

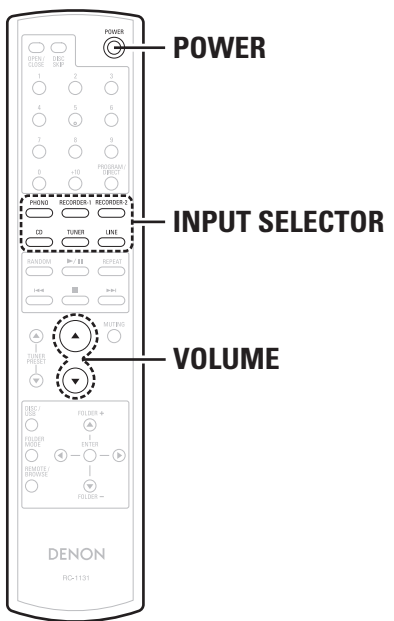
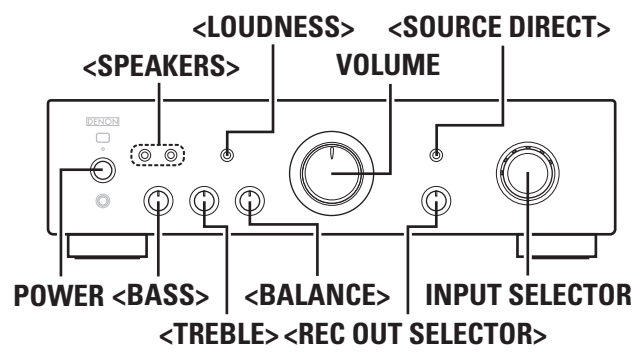

## Preparations Prior to Playing

- 1 Set the volume to the minimum by using **VOLUME**.
- 2 Set **<SOURCE DIRECT>** and **<LOUDNESS>** to "OFF".
- 3 Set **<BASS>**, **<TREBLE>** and **<BALANCE>** to the center position.
- 4 Press **<SPEAKERS>** **A** or **B** depending on the terminals to which speakers are connected.
- 5 Turn on the power by pressing **POWER**.  
The power indicator blinks red for several seconds, then lights green.

## Starting Playback

- 1 Use **INPUT SELECTOR** to select the source to be played.  
The input indicator for the selected source lights.  
[Selectable source]  
**RECORDER-2** **RECORDER-1** **PHONO** **CD** **TUNER**  
**LINE**
- 2 Play the selected source.
- 3 Adjust the volume by using **VOLUME**.
- 4 Adjust the tone with **<BASS>**, **<TREBLE>**, **<BALANCE>** and **<LOUDNESS>**.  
\* If there is no need to adjust the tone, press **<SOURCE DIRECT>**.

## Starting Recording

- 1 Turn **<REC OUT SELECTOR>** to select the source to be recorded.  
[Selectable source]  
**PHONO** **CD** **TUNER** **LINE**
- 2 Set the recorder to the record mode.
- 3 Start playing the source to be recorded.

## Copying Recorders

- 1 Turn **<REC OUT SELECTOR>** and select "RECORDER-1 ► 2" (or "RECORDER-2 ► 1").  
[Selectable source]  
**RECORDER-1 ► 2** **RECORDER-2 ► 1**
- 2 Set the device connected to the **RECORDER-1** (or **RECORDER-2**) terminal to the record mode.
- 3 Start playback on the device connected to the **RECORDER-2** (or **RECORDER-1**) terminal.

- The sound to be recorded can be heard by selecting the playback source with **INPUT SELECTOR**, while the recorded sound can be heard by selecting the recorder.
- When performing these operations, also refer to the operating instructions of the other devices.

**NOTE**

The sound may be interrupted or noise may be recorded if **INPUT SELECTOR** is operated during recording.

# Troubleshooting

If a problem should arise, first check the following:

1. Are the connections correct?
2. Is the set being operated as described in the owner's manual?
3. Are the other components operating properly?

If this unit does not operate properly, check the items listed in the table below. Should the problem persist, there may be a malfunction.

In this case, disconnect the power immediately and contact your store of purchase.

Symptom	Cause	Countermeasure	Page
When the power is turned on, the power indicator does not light and no sound is produced.	<ul style="list-style-type: none"> <li>• The power cord's plug is not fully plugged in.</li> </ul>	<ul style="list-style-type: none"> <li>• Make sure the unit is correctly plugged in and switched on at the mains socket.</li> </ul>	7
The power indicator flashes, and no sound is produced.	<ul style="list-style-type: none"> <li>• A short circuit has occurred, either due to contact between the speaker cable cores, or because a core has come loose from a terminal and is contacting the rear panel of the PMA-710AE.</li> <li>• The device's internal temperature has increased because sufficient space has not been assured around the device.</li> </ul>	<ul style="list-style-type: none"> <li>• Unplug the power cord, then after twisting the core wires together tightly again, or effecting termination treatments etc, please reconnect once again.</li> <li>• Turn off the power and ensure sufficient space around the device. And turn on the power again after the body temperature has fallen sufficiently.</li> </ul>	5, 6  1, 5
The power indicator lights but no sound is produced.	<ul style="list-style-type: none"> <li>• The speaker cables are not fully connected.</li> <li>• The device you want to listen to has not been selected.</li> <li>• The volume control is set to minimum.</li> <li>• The input cable is not fully connected.</li> <li>• The speaker selector button is set to "OFF".</li> </ul>	<ul style="list-style-type: none"> <li>• Connect securely.</li> </ul>	5, 6
		<ul style="list-style-type: none"> <li>• Insure the correct input is selected.</li> </ul>	8
		<ul style="list-style-type: none"> <li>• Set to an appropriate level.</li> </ul>	3, 4, 8
		<ul style="list-style-type: none"> <li>• Connect securely.</li> </ul>	6, 7
Sound is only produced from the left or right speaker (s).	<ul style="list-style-type: none"> <li>• The speaker cables are not fully connected.</li> <li>• The input cable is not fully connected.</li> <li>• The left/right balance is off.</li> </ul>	<ul style="list-style-type: none"> <li>• Ensure the SPEAKER A or B buttons are set to "ON" as appropriate.</li> </ul>	3
		<ul style="list-style-type: none"> <li>• Connect securely.</li> </ul>	5, 6
	<ul style="list-style-type: none"> <li>• The speaker cables are not fully connected.</li> <li>• The input cable is not fully connected.</li> <li>• The left/right balance is off.</li> </ul>	<ul style="list-style-type: none"> <li>• Connect securely.</li> </ul>	6, 7
		<ul style="list-style-type: none"> <li>• Adjust to a proper balance using the balance control knob.</li> </ul>	3, 8

Symptom	Cause	Countermeasure	Page
For stereo sound, the positions of the instruments are inverted left/right.	<ul style="list-style-type: none"> <li>• The connections of the speakers or input cables are inverted.</li> </ul>	<ul style="list-style-type: none"> <li>• Check the connections to be sure that left is connected to left, right to right.</li> </ul>	6, 7
Humming sound is heard in the music when playing records.	<ul style="list-style-type: none"> <li>• The player's ground wire is not connected.</li> <li>• The cables are not fully connected to the PHONO terminals.</li> <li>• Influence from a TV or VCR near the player.</li> </ul>	<ul style="list-style-type: none"> <li>• Connect securely.</li> </ul>	6
		<ul style="list-style-type: none"> <li>• Connect securely.</li> </ul>	6
		<ul style="list-style-type: none"> <li>• Try changing the positions in which the devices are installed.</li> </ul>	-
Howling is produced along with the music if the volume is too high when playing records.	<ul style="list-style-type: none"> <li>• The player and speakers are too close together.</li> <li>• The vibrations from the speakers are being transmitted to the player through the floor.</li> </ul>	<ul style="list-style-type: none"> <li>• Install the player and speakers as far from each other as possible.</li> </ul>	-
		<ul style="list-style-type: none"> <li>• Use cushions, etc., to absorb the speakers' vibrations.</li> </ul>	-
When playing a record, the sound is distorted.	<ul style="list-style-type: none"> <li>• The needle pressure is not proper.</li> <li>• There is dirt on the tip of the needle.</li> <li>• The cartridge is defective.</li> </ul>	<ul style="list-style-type: none"> <li>• Adjust to a proper needle pressure.</li> </ul>	-
		<ul style="list-style-type: none"> <li>• Check the tip of the needle.</li> </ul>	-
		<ul style="list-style-type: none"> <li>• Replace the cartridge.</li> </ul>	-

# Specifications

## Power amplifier section

**Rated Output Power:** 2-channel driving (CD → SP OUT)  
50 W + 50 W (8 Ω/ohms, 20 Hz ~ 20 kHz, T.H.D. 0.07 %)  
85 W + 85 W (4 Ω/ohms, DIN, 1 kHz, T.H.D. 0.7 %)

**Dynamic power:** 0.01 % (Rated output: -3 dB), 8 Ω/ohms, 1 kHz

**High frequency distortion:** Speaker A or B: 4 ~ 16 Ω/ohms  
A + B: 8 ~ 16 Ω/ohms

**Output terminals:** Suited for headphones/stereo headphones

## Pre amplifier section

**Equalizer amplifier output:** 150 mV  
(REC OUT terminals)

**Input Sensitivity/Input Impedance:** PHONO (MM): 2.5 mV/47 kΩ/kohms  
CD, TUNER, LINE, RECORDER-1, RECORDER-2:  
105 mV/47 kΩ/kohms (SOURCE DIRECT OFF)  
105 mV/13 kΩ/kohms (SOURCE DIRECT ON)

**RIAA Deviation:** PHONO (MM): 20 Hz ~ 20 kHz ±0.5 dB

## Overall performance

**SN Ratio (A network):** PHONO (MM): 86 dB  
(With input terminals short-circuited, 5 mV input signal)  
CD, TUNER, LINE, RECORDER-1, RECORDER-2:  
107 dB (input terminals short-circuited)

**Tone control (bass):** BASS: 100 Hz ±8 dB  
TREBLE: 10 kHz ±8 dB

**LOUDNESS:** 100 Hz: +6 dB, 10 kHz: +6 dB

## General

**Power supply:** AC 230 V, 50 Hz

**Power consumption:** 200 W  
0.3 W (Standby)

**Power outlets:** 3 switched outlets, total capacity 100W (0.43A)

**Maximum external dimensions:** 434 (W) x 121 (H) x 307 (D) mm

**Weight:** 6.7 kg

## Remote control unit (RC-1131)

**Batteries:** R03/AAA Type (two batteries)

**Maximum external dimensions:** 49 (W) x 220 (H) x 21 (D) mm

**Weight:** 120 g (including batteries)

\*: For purposes of improvement, specifications and design are subject to change without notice.

# Index

## A

Adjust the tone.....8  
Adjust the volume.....8

## B

BALANCE .....3  
BASS .....3  
Batteries .....2  
Bi-wiring Connection.....6

## C

Cables Used for Connections .....5  
Connecting Players .....6  
Connecting Recorders .....7  
Connecting the Speakers.....5  
Copying Recorders.....8

## I

INPUT SELECTOR .....8

## L

LOUDNESS.....3

## P

Power cord.....7  
Protection circuit.....5

## S

SOURCE DIRECT.....3  
Speaker cables .....5  
SPEAKERS A/B .....3  
Stereo pin-plug cable.....5

## T

TREBLE .....3

## V

VOLUME.....3

**DENON**

[www.denon.com](http://www.denon.com)

Denon Brand Company, D&M Holdings Inc.  
Printed in China 5411 10316 004D